

SITE DATA

TOTAL ACRES	± 63.63 ACRES
TOTAL UNITS @ 62' X 120' LOTS	95 UNITS
DENSITY	± 1.49 D.U./AC.
OPEN SPACE	± 38 ACRES
PERCENTAGE OF OPEN SPACE	± 60 %

VICINITY MAP

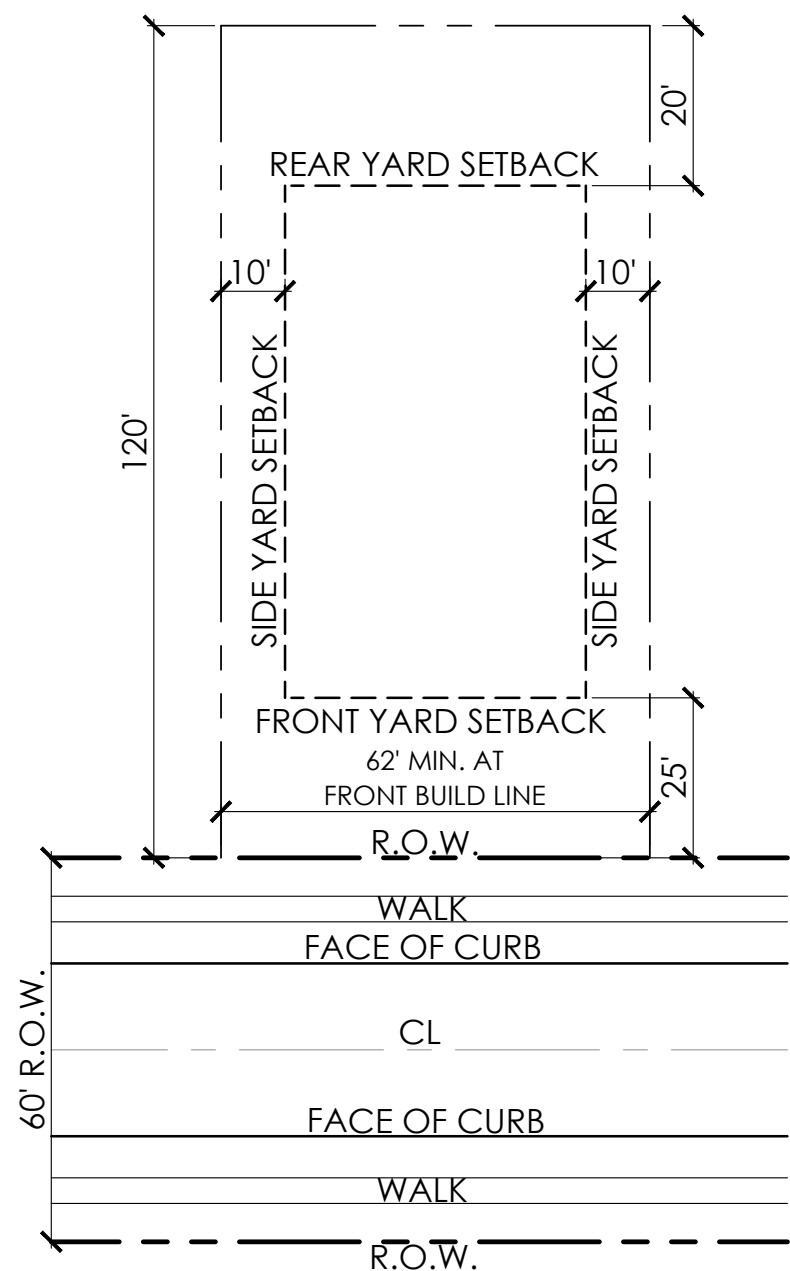

① TYP. 62' X 120' LOT CONFIGURATION
SCALE: 1" = 30'

PRELIMINARY DEVELOPMENT PLAN

EXHIBIT C-1

CLARKSHAW VILLAGE

PREPARED FOR: MARONDA HOMES
DATE: 5.22.2024

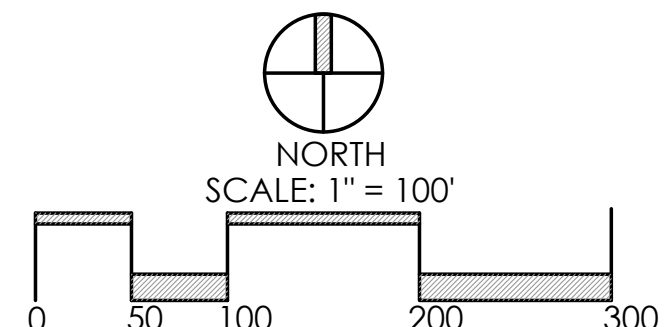

Faris Planning & Design
LAND PLANNING LANDSCAPE ARCHITECTURE

4876 Cemetery Road Hilliard, OH 43026
p (614) 487-1964 www.farisplanninganddesign.com