

PRD EXECUTIVE SUMMARY

This serves to highlight documents added/changed to the July 29, 2015 submission for a Planned Residential District at parcel #319-220-01-049-000 and 319-220-01-046-000 on South Section Line Road in Concord Township.

- 1.) Application for PRD text: Page 2– Item 11.03.a. Clarification for the type of new dwelling unit the existing home can be rebuilt as.
- 2.) Application for PRD text: Page 2– Item 11.03.d. The addition of a sales trailer would be added as a temporary non-residential structure.
- 3.) Application for PRD text: Page 5– Item 11.06.a. Added line for the date of zoning approval.
- 4.) Application for PRD text: Page 5– Item 11.06.b.2 Clarification that the existing or replacement home shall be exempt from joining a Condominium Association.
- 5.) Application for PRD text: Page 7–Item 11.06 .b.5 updated to note right-in/right-out off South Section Line Road and connection to St. Laurent Drive.
- 6.) Application for PRD text: Page 10– Item 11.07.b.1 Clarification that the existing or replacement home shall be exempt from becoming condominium units within a Condominium Association.
- 7.) Exhibit A-1 – Surrounding Property Owners has been updated.
- 8.) Exhibits C-1, C-2, D-1, D-2, E-1, and J-1 updated to show R.I.R.O. on South Section Line Road and addition of drive connecting to St. Laurent Drive on east, as well as additional planting along South Section Line Road.
- 9.) Exhibit E-8 – Concord Township Fire Letter has been added.
- 10.) Table of Contents has been updated to reflect the addition of Exhibit E-8 – Concord Township Fire Letter.

TABLE OF CONTENTS

APPLICATION FOR AMENDMENTS

- Application

DEVELOPMENT PLAN TEXT

Tab 1

- PRD-Planned Residential District

EXHIBITS

Tab 2

- EX. A-1 : Surrounding Property Owners

Tab 3

- EX. B-1 : Legal Description

Tab 4

- EX. C-1 : Development Plan
- EX. C-2 : Phasing Plan

Tab 5

- EX. D-1 : Overall Landscape Plan
- EX. D-2 : Entry Landscape Enlargement Plan
- EX. D-3 : Typical Unit Planting Plans
- EX. D-4 : Open Space Plan
- EX. D-5 : Site Plan Comparison
- EX. D-6 : Buffer Sections

Tab 6

- EX. E-1 : Utility Plan
- EX. E-2 : Delaware County Sewer Letter
- EX. E-3 : Delco Water Letter
- EX. E-4 : AEP Electric Letter
- EX. E-5 : Columbia Gas Letter

- EX. E-6 : Frontier Cable Letter
- EX. E-7 : Traffic Study
- EX. E-8 : Concord Township Fire Letter

Tab 7

- EX. F-1 : Sample Declaration of Covenants/Deed Restrictions

Tab 8

- EX. G-1: Population Demographics

Tab 9

- EX. H-1: Architectural Character Elevations
- EX. H-2: Rear Elevations

TAB 10

- EX. I-1: Typical Pavement Sections

Tab 11

- EX. J-1: Lighting Plan

Application for Planned Residential District (PRD)

August 19, 2015

Property Address: 7337 South Section Line Road

Parcel No.: 319-220-01-049-000 and 319-220-01-046-000

Applicant: Joel D. Rhoades
Epcon Communities
500 Stonehenge Parkway
Dublin, Ohio 43017
Phone: 614-761-1010

Land Planner: Todd Faris
Faris Planning & Design
243 North Fifth Street
Suite 401
Columbus, Ohio 43215
Phone: 614-487-1964

ARTICLE XI - PLANNED RESIDENTIAL DISTRICT (PRD)

Section 11.01 - PURPOSE: The Township, recognizing that with increased residential areas which take into account unique natural features, contemporary land use concepts, and a balanced residential environment, hereby provides for the Planned Residential District intending hereby to promote the variety and flexibility of land development for residential purposes that are necessary to meet these demands while still preserving and enhancing the health, safety and general welfare of the inhabitants of Concord Township.

Section 11.02 - APPLICATION: The provisions of this article of the Zoning Resolution may be applied only to lands of the Township that have been approved for a zoning map amendment to PRD. An owner of the land in the township that is served by centralized water and sanitary sewer may submit an application of change to PRD zoning under the provisions of this Article. The action of the Township upon an application processed pursuant to this section shall be considered a legislative act, subject to referendum.

Section 11.03 - PERMITTED USES: Within the Planned Residential District (PRD), the following uses, developed in strict compliance with the approved development plan and standards, shall be permitted:

- a) Residential structures may be either single family or multi-family.

This zoning district will consist of 66 single family homes as shown on Exhibit C-1 Development Plan. Of these, one will be the single-family home now existing on the property (some existing agricultural buildings will be removed in the course of development while others will be maintained, at the developer's sole discretion and as

necessary to accommodate the proposed development). At the property owner's discretion, either now or in the future, the existing single-family home (and remaining ancillary buildings, if any) may be removed and one additional new, condominium dwelling may be built in its place. *This new dwelling could be a traditional single-family house, at the property owner's sole discretion, but in all events will not exceed one dwelling unit and ancillary structures.*

b) Nonresidential uses of a religious, cultural, educational or recreational nature or character to the extent that they are designed and intended to serve the residents of the Planned Residential District. Said facilities may be designed to serve adjoining neighborhoods or residents if they are located in such proximity to the major thoroughfares as to permit access without burdening residential streets.

This use will not be permitted in this zoning district.

c) Public or Private golf courses, country clubs, fishing lakes or similar recreational uses with all buildings and club houses incident thereto including restaurant to serve members and/or users of the facility.

This use will not be permitted in this zoning district.

d) Temporary structures such as mobile office and temporary buildings of a nonresidential character may be used incident to construction work on the premises, or on adjacent public projects, or during a period while the permanent dwelling is being constructed. The user of said structure shall obtain a permit for such temporary use, which shall be valid for six (6) months and may be renewed not more than twice. Renewal of the permit shall be at the discretion of the Zoning Inspector on finding of reasonable progress toward completion of the permanent structure or project. The Zoning Inspector may require provisions for sanitary waste disposal and water supply, as he/she deems necessary. The fees for such permit and renewals thereof shall be established by the Board of Township Trustees. Said temporary structure shall be removed no later than ten (10) days after expiration of said permit.

It is not anticipated that there will be a need for temporary non-residential structures, other than a construction trailer and sales trailer. Should temporary non-residential structures be necessary for this zoning district, the proper permits will be obtained as required by the Township Zoning Resolution.

Section 11.04 - CONDITIONAL USES: Within the PRD zoning, district the following uses may be permitted, subject to the conditions and restrictions imposed by the Board of Zoning Appeals (BZA) pursuant to the provisions of Article XXVIII of this Resolution. Conditionally permitted uses shall be considered abandoned if said use or uses are not commenced within one (1) year from the date of BZA approval or are discontinued for a period in excess of two (2) years. Unless the conditional use permit specifically provides that the grant shall be permanent

and shall run with the land, the sale or conveyance of the land and or structure wherein the same is located or upon which the same is granted shall void the conditional use permit, and the subsequent owner(s) or his/her agent shall be required to apply for a continuation and/or modification of such use(s) to the BZA. A designation by the BZA that a permit is permanent and shall run with the land does not affect the right of authorities to seek redress for failure to comply with conditions imposed. No conditional use shall be implemented until a conditional use permit is issued by the Zoning Inspector.

a) Customary Home Occupations, which are clearly incidental and secondary to residential use, conducted by the resident of a permitted dwelling are subject to the requirements of Section 21.12.

This zoning district will meet the Home Occupation Requirements

b) Group homes or residential care facilities in which not more than six (6) persons are provided with room, board, specialized care, rehabilitative services, and supervision in a family environment. All such facilities shall have all approvals and/or licenses as required by state or local agencies. In addition to all other conditions deemed necessary, the following conditions shall be imposed by the Board of Zoning Appeals:

- 1) The facility shall comply with Section 11.07, Development Standards.
- 2) No exterior alterations of the structure shall be made which depart from the residential character of the building. All new structures shall be compatible in residential design with the surrounding neighborhood.
- 3) No Group Home should be located within a one (1) mile radius of another such facility.

This use will not be permitted in this zoning district.

c) Model Homes, the same being defined as residential type structures used as sales offices by builders/developers and to display the builder's/developer's product. The same may be furnished within, since its purpose is to display to prospective buyers the builder's/developer's features (such as exterior siding treatment, roofing materials, interior trim, moldings, floor covering, etc.) in the environment of a completed home. Model homes may be staffed by the builder's/developer's sales force. Model homes shall be subject to the following restrictions:

This zoning district will meet the Model Home requirements. Requirements are as follows:

- 1) Hours of operation: All model homes shall be closed between 9:00 P.M. and 9:00 A.M.
- 2) Lighting: All exterior lighting must be downlighting, so that no light shall be cast onto adjoining residential properties. All off-street parking areas must be illuminated. All exterior lighting shall be extinguished at the closing time of the model home.

3) Parking: All model homes shall provide off-street paved parking for the public. Such off-street paved parking shall be located as directed by the Board of Zoning Appeals. The number of required parking spaces shall be six (6) per model home.

4) Screening and trash receptacles: Landscape drawing shall be required and shall show adequate landscape and screening from adjoining residential lots, together with the clear marking of the boundaries of the model home lot. Trash receptacles shall be provided around the model home for use by the public.

5) Termination of use: The use of model homes within a residential subdivision, or within any single phase of a multi-phase subdivision, shall terminate when building permits have been issued for ninety percent of the lots therein.

Section 11.05- PROHIBITED USES

This zoning district will not contain any of the Prohibited Uses as set forth herein.

a) Any use not specifically authorized by the express terms of this article of the Zoning Resolution shall be prohibited.

b) Outdoor storage of inoperable or unlicensed motor vehicles for a period exceeding fourteen (14) days is prohibited. Said vehicles, if stored on the premises, shall be enclosed within a building so as not to be visible from any adjoining property or public road.

c) No motor home, trailer, camper, boat nor equipment of any type shall be parked in front of the front building line on any lot within this district for more than twenty-four (24) hours in any ten (10) day period. If a dwelling is located on said lot, the building line shall be considered to be the front wall of the dwelling even if said dwelling is located behind the minimum building line established by this Resolution, or the restrictions in the plat, deed, or development plan.

d) No motor home, mobile home or camper of any type may be occupied by a guest of the resident/owner for more than fourteen (14) days. No more than one motor home, trailer, or camper may be occupied for such a period on any lot of record.

Except as specifically permitted in Section 11.03 (d), no manufactured/mobile home shall be placed or occupied in this district. Modular structures in compliance with the Ohio Building Code and designed for placement on a permanent foundation are acceptable.

e) Agricultural activities as prohibited in Section 6.02 of this Resolution.

f) No trash, debris, unused property, or discarded materials which create an eyesore, hazard or nuisance to the neighborhood or general public shall be permitted to accumulate on any lot or portion thereof.

Section 11.06 – PROCEDURE: In addition to any other procedures set out in this

Resolution, all applications for amendments to the zoning map to rezone lots to this PRD district shall follow the procedures hereinafter set forth:

a) Application - The owner or owners of lots within the Township may request that the zoning map be amended to include such lots in the Planned Residential District in accordance with the provisions of this Resolution.

The developer is submitting the “Property” (hereinafter defined) for consideration of a zoning change from FR-1 to a Planned Residential District (PRD).

The applicant is encouraged to engage in informal consultations with the Zoning Commission prior to formal submission of a development plan and request an amendment of the zoning map, understanding that no statement by officials of the Township shall be binding upon either.

The applicant met informally with the Township zoning inspector and with Delaware County Regional Planning. Zoning was approved by the Township on January, 21, 2015.

b) Development Plan - Ten (15) copies of the development plan shall be submitted to the Zoning Commission with the application, which plan shall include in text and drawing form the following:

1) The proposed boundaries, size and location of the Planned Residential District drawn to scale.

This zoning district consists of approximately 26.62 acres. The legal description has been submitted as part of the zoning application and is attached hereto as Exhibit B-1.

2) The general development character of the lot including the limitations or controls to be placed on residential and related uses, with probable lot sizes, minimum setback requirements, structure location, and other development features including landscape.

See Development Plan attached hereto as Exhibit C-1 and Sample Deed Restrictions attached hereto as Exhibit F-1.

Each owner of a dwelling (with the exception of the existing *or replacement* single-family home, until such time, if any, that it is removed and replaced as described herein above) shall be a member of a condominium unit owners association which will own and maintain the open space. The Condominium Association shall be formed prior to the closing on the sale of the first home from the developer. Prior to time the Condominium Association is created, the property will be maintained by the developer.

The development will meet the tree requirements set forth in Section 23.03 D (2) (a) of the Township zoning code. Also see Landscape Plan attached as Exhibit D-1.

3) Architectural design criteria for all structures and criteria for proposed signs with proposed control procedures.

The exteriors of the homes constructed shall be comprised entirely of stone, brick, cultured stone, EIFS, wood (including engineered wood), cementitious fiber or stucco, or a combination thereof, except for gutters, soffits and overhangs, entry doors, garage doors

and other accents. Aluminum and/or vinyl may be used for trim details such as soffits, gutters, shutters, etc.

All homes will have a minimum eight (8) inch overhangs, a minimum roof pitch of 6/12 on the main structures of the home (accent features such as porches and dormers may have less than 6/12 roof pitch), all front windows will be wrapped with a minimum of four (4) inch wood trim (except when the windows are surrounded by stone or brick) and the garage doors will either have raised panels or decorative accents.

Exterior finishes containing high gloss or high chroma colors are prohibited on all structures within the property. The same front elevations and/or color treatment shall not be repeated for any home located within one (1) lot on either side or directly across the street from the subject home.

See Exhibit F-1 for Sample Deed Restrictions.

See Exhibit D-2 for specifications and limitation for signage for entranceway.

Lot sizes as shown on the Development Plan are subject to final engineering. Notwithstanding the foregoing, the number of lots shall not be increased.

4) The proposed provisions for water, sanitary sewer and surface drainage with engineering feasibility studies or other evidence of reasonableness.

Water

See Exhibit E-1 for Engineering Feasibility Plan and Exhibit E-3 for Delco Water Serviceability Letter.

Sanitary

See Exhibit E-1 for Engineering Feasibility Plan and Exhibit E-2 for Delaware County Sanitary Engineer Letter.

Surface Drainage

All surface and subsurface storm water provisions will comply with the Delaware County Engineer's Regulations, including detention and retention requirements, subject to any waivers granted by the county Engineer's office. The proposed storm water drainage facilities (basins) are shown on the plan. All retention facilities will be wet ponds and storm water quality basins shall be dry. See Exhibit C-1 for Development Plan and Exhibit E-1 for Engineering Feasibility Plan.

All utilities will be underground except for electric and telephone pedestals and/or any other similar appurtenances necessary to service this zoning district.

5) The proposed traffic patterns showing public and private streets and other transportation facilities, including their relationship to existing conditions, topographically.

Access includes a right-in/right-out off South Section Line Road along with a connection to St. Laurent Drive to the East of the site, each as shown on the Development Plan attached as Exhibit C-1.

6) The relationship of the proposed development to existing and probable uses of surrounding areas during the development timetable. Include a list of owners and addresses whose property is contiguous to and directly across from the applicant's property according to the most recent County Auditor's tax list.

The site is surrounded by FR-1 (to the north, south, and west) and PRD (Scioto Reserve, to the east), which has been developed with single-family homes.

7) The proposed size, location, and use of nonresidential portions of the lot including usable open areas, parks, paths, school sites, and other areas with their suggested ownership.

See Development Plan attached as Exhibit C-1 for open space areas and pathways.

8) The proposed time schedule for development of the site including streets, buildings, utilities and other facilities.

If zoning is approved, construction will start in 2015. See the Phasing Plan attached as Exhibit C-2.

9) If the proposed timetable for development includes developing the land in phases, all phases to be developed after the first, which in no event shall be less than five (5) acres or the whole tract (whichever is smaller), shall be fully described in textual form in a manner calculated to give township officials definitive guidelines for approval of future phases.

See the Phasing Plan attached as Exhibit C-2.

10) The ability of the applicant to carry forth his/her plan by control of the land and the engineering feasibility of the plan. If the applicant is not the owner, the applicant must have written authorization from the owner.

The applicant is currently under contract to purchase the property.

11) Specific statements of divergence from the development standards in Article XXI or existing county regulations or standards and the justification therefore. Unless a variation from these development standards is specifically approved, the same shall be complied with.

No divergences are requested.

12) Evidence of the applicant's ability to post a bond if the plan is approved ensuring completion of public service facilities to be constructed within the project by the developer.

At the time of approval of the subdivision plat and engineering plans, a letter of credit from the Developer will be submitted to Delaware County.

c) Criteria for Approval - In approving an application for a Planned Residential District, the reviewing authority shall determine:

1) If the proposed development is consistent in all respects with the purpose, intent, and general standards of this Zoning Resolution.

See Development Plan attached as Exhibit C-1. The density is 2.48 units/ acre.

2) If the proposed development is in conformity with the comprehensive plan or portion thereof as it may apply.

The proposed development is compatible with the comprehensive plan.

3) If the proposed development advances the general welfare of the township and the immediate vicinity.

Single family homes are appropriate for this site. It is surrounded by other single-family homes with which it will be compatible in style and value. The proposed homes will be primarily targeted to empty-nesters and seniors, a growing population segment within the township and having less impact on public infrastructure than traditional single-family on platted lots. See Exhibit G-1 for Population Demographics.

d) Effect of Approval - The Development Plan as recommended for approval by the Zoning Commission and approved by the Township Trustees shall constitute all amendment to the Zoning Resolution as it applies to the lands included in the approved amendment. The approval shall be for a period of three (3) years to allow the preparation of plats required by the Subdivision Regulations of Delaware County, Ohio.

Where the land is to be developed in phases, plans for phases subsequent to the first phase shall be submitted in accordance with the timetable in the approved development plan. Unless the required plats are properly recorded and work on said development commenced within three (3) years, the approval shall be voided and the land shall automatically revert to the previous District unless the application for time extension is timely submitted and approved.

e) Extension of Time or Modification - An extension of the time limit or a modification of the approved development plan may be approved by the Zoning Commission and the Township Trustees. Such approval shall be given only upon a finding of the purpose and necessity for such change or extension and evidence of reasonable effort toward the accomplishment of the original development plan, and that such extension or modification is not in conflict with the general health, welfare and safety of the public or development standards of the district. No extension of time shall be granted except on application filed with the Township Zoning Inspector not later than ninety (90) days before the expiration of the three (3) year period prescribed in Section 11.06 (d) as hereinbefore set forth.

f) Site Plans Required - In the Planned Residential District (PRD), no use shall be established or changed, and no structure shall be constructed or altered until the required subdivision plat has been prepared and recorded in accordance with the Subdivision Regulations for Delaware County, Ohio, and this Resolution. The subdivision plat shall be in accord with the approved development plan and shall include:

1) Site arrangement, including building setback lines and space to be built upon within the site; water, fire hydrants, sewer, all underground public utility installations, including sanitary sewers, surface drainage and waste disposal facilities; casements, access points to public right-of-way; and land reserved for non-highway service use with indication of the nature of such use.

See Development Plan attached as Exhibit C-1.

2) Deed restrictions, covenants, easements and encumbrances to be used to control the use, development and maintenance of the land, the improvements thereon, and the activities of occupants, including those applicable to areas within the lot to be developed for nonresidential uses.

See Sample Deed Restrictions attached as Exhibit F-1.

3) In the event that any public service facilities not to be otherwise guaranteed by a public utility have not been constructed prior to recording of the plat, the owner of the project shall post a performance bond in favor of the appropriate public officers in a satisfactory amount ensuring expeditious completion of said facilities within one (1) year after the recording of said plat. In no event, however, shall any zoning certificate be issued for any building or use until such time that the facilities for the phase in which the building or use is located are completed.

At the time of approval of the engineering plans, a letter of credit from the Developer will be submitted to Delaware County.

g) Administrative Review - All plats, construction drawings, restrictive covenants and other necessary documents shall be submitted to the Zoning Inspector or his/her designated technical advisors for administrative review to ensure substantial compliance with the development plan as approved. The Board of Trustees may, from time to time, establish fees to be deposited for each administrative review in order to defray the costs associated with such review.

Section 11.07 – DEVELOPMENT STANDARDS: In addition to any other provisions of this Resolution the following standards for arrangement and development of lands and buildings are required in the Planned Residential District:

a) Intensity of Use - The maximum density shall be one and one-half (1 1/2) dwelling units per gross acre within the area to be developed, unless the physical boundaries of land or existing developments adjacent thereto on adjoining lands establish an atmosphere inconsistent with the above maximum density of one and one half (1 1/2) dwelling units per gross acre. Increased densities of one-half dwelling unit per quality item may be approved by the Concord Zoning Commission and Township Trustees if it is determined that any of the following quality items are included in the development plan:

- 1) If the property is directly adjacent and easily accessible to major thoroughfares.
- 2) If the property is directly adjacent and easily accessible to publicly controlled and maintained community recreational facilities or service.
- 3) If the developer provides usable parks or public open or recreational space as part of the design of the development.
- 4) If pedestrian or bike trails are provided as part of the design of the development.
- 5) The retention and protection of natural or historic areas.

The Zoning Commission may recommend and Township Trustees may approve zoning incentives of up to one-half (1 /2) unit per gross acre for each of the above standards of quality found to exist; however, the total density for the entire area of the development shall not exceed three (3) units per gross acre.

For purposes of development within the Planned Residential District in Concord Township, the maximum density for development shall be as follows:

Type Dwelling Maximum Dwelling Units per Gross Acre

Single Family 1 1/2 (plus incentive units)

Multi-family 6

The applicant is requesting a density of 2.48 units / acre. The site meets the above requirements for increased density.

b) Arrangement of Structures

1) Setback Line - The physical relationships of buildings and uses and their minimum yard spaces shall be developed in compliance with the approved plan and the provisions of Article XXI unless a variance is approved.

All dwellings, with the exception of the existing single-family home or its replacement, will be condominium units within a Condominium Association to be established by the developer. See Development Plan attached as Exhibit C-1.

2) Building Height Limits - No building in this district shall exceed thirty-five (35) feet in height measured from the finished grade established not closer than fifteen (15) feet to the exterior wall of the structure. Barns, silos, grain bins, grain handling conveyors, church spires, domes, flag poles and elevator shafts are exempted from any height regulation and may be erected to any safe height. No windmill, aerial, antenna or tower shall be constructed to a height greater than the distance from the center of the base thereof to the nearest property line of said lot.

This zoning district will meet the building height limitation requirements.

c) Building Dimension (Floor space requirements) - Each single family dwelling hereafter erected in this district shall have a living area not less than one thousand (1000) square feet. All such living areas shall be exclusive of basements, porches or garages.

All multi-family buildings constructed within this district shall contain the following minimum living area, to wit:

One (1) bedroom unit 800 square feet

Two (2) bedroom unit 950 square feet

Three or more bedroom units 1000 square feet

d) Landscape - All yards, front, side and rear, shall be landscaped, and all organized open spaces or nonresidential use areas shall be landscaped. Such landscape plans shall be submitted with the zoning application and shall meet the requirements of Article XXIII

This zoning district will meet the Building Dimension requirements.

e) Site Development - To the maximum extent possible, all natural drainage courses, vegetation, and contours in excess of six (6%) percent shall be maintained.

This zoning district will meet the above requirement.

f) Parking - Off-street parking shall be provided at the time of construction of the main structure or building with adequate provisions for ingress and egress according to the development plan. In preparing and approving the parking plan, provisions of Article XXI shall be incorporated when appropriate.

Each home will have at least a two-car garage as well as two parking spaces available in the driveway.

g) Signs - Except as provided under the provisions of this article for home occupations or as controlled by Article XXII and except as permitted by the Board of Zoning Appeals incident to Conditional Uses, no signs shall be permitted in this district except a "For Sale" or "For Rent" or "For Lease" sign advertising the tract on which the said sign is located. Such sign shall not exceed four (4) square feet in area on either side.

The owner or developer of a subdivision or similar area, upon the conditions and for the time period established by the Zoning Commission, may erect one sign not exceeding thirty-two (32) square feet in area per side advertising said subdivision, development or lot for sale.

See entranceway signage as shown on Exhibit D-2.

h) Construction and Maintenance of Improvements Within Right-of-Way: Unless otherwise specifically required by applicable law, the construction and maintenance of all improvements behind the curb line or the edge of pavement including but not limited to drainage improvements,

landscape improvements, sidewalks and/or driveways approaches shall be the responsibility of the abutting property owner.

This zoning district will meet the above requirement.

i) Special Additional Conditions - The Township Zoning Commission may recommend and the Township Trustees may impose special additional conditions relating to the development with regard to type and extent of public improvements to be installed; landscape, development, improvement, and maintenance of common open space any other pertinent development characteristics.

j) Exterior Lighting - All exterior lighting fixtures will be shaded wherever necessary to avoid casting direct light upon any adjoining property located in a Residential District.

This zoning district will meet the above requirement.

k.) Performance Standards - All uses within this district shall be in compliance with the provisions of Article XXI, Section 21.11.

This zoning district will meet the above requirement.

l.) Accessory building- No part of any accessory building shall be located in the front yard.

This zoning district will meet the above requirement.

AMUNDSON JACK L EMMALEE W
7481 S SECTION LINE RD
DELAWARE, OH 43015

CITY OF COLUMBUS
5770 RIVERSIDE DR
DELAWARE, OH 43015

ARNHOLD JONATHAN R ANNMARIE
7200 SCIOTO PKWY
POWELL, OH 43065

CITY OF COLUMBUS
5300 FRONT ST
DELAWARE, OH 43015

BEATTY MICHAEL A LORI L
7178 SCIOTO PKWY
POWELL, OH 43065

CITY OF COLUMBUS
7600 RIVERSIDE DR
DELAWARE, OH 43015

BEELEY LUCAS D
7516 FAIRFIELD LAKES DR
POWELL, OH 43065

CITY OF COLUMBUS
7690 RIVERSIDE DR
DELAWARE, OH 43015

BELL DAVID
7133 S SECTION LINE RD
DELAWARE, OH 43015

CITY OF COLUMBUS
8080 RIVERSIDE DR
DELAWARE, OH 43015

BOSSE LAURA
7505 FAIRFIELD LAKES DR
POWELL, OH 43065

CITY OF COLUMBUS
6020 RIVERSIDE DR
DELAWARE, OH 43015

BOYD JOHN C & KIMBERLY ANN
7378 FAIRFIELD LAKES DR
POWELL, OH 43065

CITY OF COLUMBUS
8420 RIVERSIDE DR
DELAWARE, OH 43015

CAMERON KEVIN D CHRISTINE M
7492 FAIRFIELD LAKES DR
POWELL, OH 43065

COTTRILL MICHAEL W & IRIS B
7462 FAIRFIELD LAKES DR
POWELL, OH 43065

CARTER G THOMAS FRIEDA B

EMLEY FRED W SHARON J
7450 FAIRFIELD LAKES DR
POWELL, OH 43065

CHRIST MICHAEL L & CHERYL M
7544 FAIRFIELD LAKES DR
POWELL, OH 43065

ENGELHAUPT MICHAEL & EVON
7168 SCIOTO PKWY
POWELL, OH 43065

CITY OF COLUMBUS
8260 RIVERSIDE DR
DELAWARE, OH 43015

FINGERHUT PETER A & JONI M
5092 SHADOW WOODS CT
POWELL, OH 43065

GIEDLINSKI LOU ANN ANTHONY F JR
5191 SOUTH LAKE HILL RD
DELAWARE, OH 43015

GILLESPIE PAUL BRIAN & BUYER MICHELLE
5085 SHADOW WOODS CT
POWELL, OH 43065

GOODWIN MARK W RENE Y
7098 S SECTION LINE RD
DELAWARE, OH 43015

GOODWIN MARK W RENE Y
0 S SECTION LINE RD
DELAWARE, OH 43015

HILLIER KEVIN C & JULIE M
7495 FAIRFIELD LAKES DR
POWELL, OH 43065

HURLEY ROBERT E EILEEN G
4949 NORTH LAKE HILL RD
DELAWARE, OH 43015

HUSS MAUREEN P
5086 SHADOW WOODS CT
POWELL, OH 43065

HUTCHINSON JOHN A CATHERINE M
7536 FAIRFIELD LAKES DR
POWELL, OH 43065

JC LAND COMPANY LTD

JONES HUGH & PATTI
7388 FAIRFIELD LAKES DR
POWELL, OH 43065

KARN DAVID P & PATRICIA L
7400 S SECTION LINE RD
DELAWARE, OH 43015

KEEGAN LAUREL J MARK
7093 S SECTION LINE RD
DELAWARE, OH 43015

KNUEVEN KATTI L & ZARINS MARKUS D
7306 SCIOTO PKWY
POWELL, OH 43065

KOCH JAMES J & LISA
7506 FAIRFIELD LAKES DR
POWELL, OH 43065

KOPIASZ JASON & SIBEL
7228 SCIOTO PKWY
POWELL, OH 43065

KROEGER SEAN & ROBYN
7410 FAIRFIELD LAKES DR
POWELL, OH 43065

KURALY MATTHEW
7242 SCIOTO PKWY
POWELL, OH 43065

LANDRY GHYSLAIN
7478 FAIRFIELD LAKES DR
POWELL, OH 43065

MCDONALD SCOTT I
7352 S SECTION LINE RD
DELAWARE, OH 43015

MORAN MICHAEL L KAREN L
7236 S SECTION LINE RD
DELAWARE, OH 43015

MORENO JACK A JAYNE E
7490 S SECTION LINE RD
DELAWARE, OH 43015

MORETZ DAVID & JACQUELINE
5075 SHADOW WOODS CT
POWELL, OH 43065

OKE KEDAR & NANDA JASMINE
7400 FAIRFIELD LAKES DR
POWELL, OH 43065

PARIKH PRADEEP & MALA P
7422 FAIRFIELD LAKES DR
POWELL, OH 43065

PARK JOON MAN & CHUNG SOON
7456 S SECTION LINE RD
DELAWARE, OH 43015

PAYNE PAUL J & CHRISTINA E
7212 SCIOTO PKWY
POWELL, OH 43065

PINNEY KENNETH D CHRISTINE E
7258 S SECTION LINE RD
DELAWARE, OH 43015

PRICE THOMAS E JAMES A & WILLIAM L

PRICE THOMAS E JAMES A & WILLIAM L
7337 S SECTION LINE RD
DELAWARE, OH 43015

PUTHIYAVEEDU SANDHYA K & CHINTALAPUDI VINOD K
5147 ST LAURENT DR
POWELL, OH 43065

QUARANTO ANTHONY R & PATRICIA CLAIRE
5211 SOUTH LAKE HILL RD
DELAWARE, OH 43015

RICHARDS EL JAY & CHRISTINA K
7284 SCIOTO PKWY
POWELL, OH 43065

SCIOTO RESERVE MASTER
ASSOCIATION INC

SCIOTO RESERVE MASTER
ASSOCIATION INC

SCIOTO RESERVE MASTER
ASSOCIATION INC

SMYERS HARLAND R & JANEL S
5093 SHADOW WOODS CT
POWELL, OH 43065

SPAIN STEVEN D & SARAH W
7304 S SECTION LINE RD
DELAWARE, OH 43015

STOCKDALE ROBERT G & PAMELA S
7296 S SECTION LINE RD
DELAWARE, OH 43015

TARACKO JOHN A CURLIS NOLA M
5177 SOUTH LAKE HILL RD
DELAWARE, OH 43015

TARRIER RANDY
7294 SCIOTO PKWY
POWELL, OH 43065

TORJAK RYAN F & WEHRLY JENNIFER M
7358 FAIRFIELD LAKES DR
POWELL, OH 43065

TRIMBLE MARIAN A
7212 S SECTION LINE RD
DELAWARE, OH 43015

WILKER RANDOLPH A & MARY E
7190 SCIOTO PKWY
POWELL, OH 43065

WILLIAMSON KELLY A & DAVID B
7428 S SECTION LINE RD
DELAWARE, OH 43015

WILLIAMSON TERRY DONNA J TRUSTEES
7380 S SECTION LINE RD
DELAWARE, OH 43015

WOLTER KURT E
7436 FAIRFIELD LAKES DR
POWELL, OH 43065

WOOD VAN E CAROL M
7332 S SECTION LINE RD
DELAWARE, OH 43015

WOOD WILLIAM H & ERICA M
7526 FAIRFIELD LAKES DR
POWELL, OH 43065

YEAGER CHRISTOPHER J & ALISON J
7368 FAIRFIELD LAKES DR
POWELL, OH 43065

ZIPF BELINDA P
7164 S SECTION LINE RD
DELAWARE, OH 43015



SITE DATA	
TOTAL ACRES	+/- 26.62 ACRES
TOTAL UNITS	66 UNITS
DENSITY	+/- 2.48 D.U./AC.
OPEN SPACE	=/- 11.13 AC.
%OPEN SPACE	=/- 41.8 %

ILLUSTRATIVE PLAN

THE COURTYARDS AT SOUTH SECTION LINE

PREPARED FOR EPCON COMMUNITIES

DATE: 7.29.15

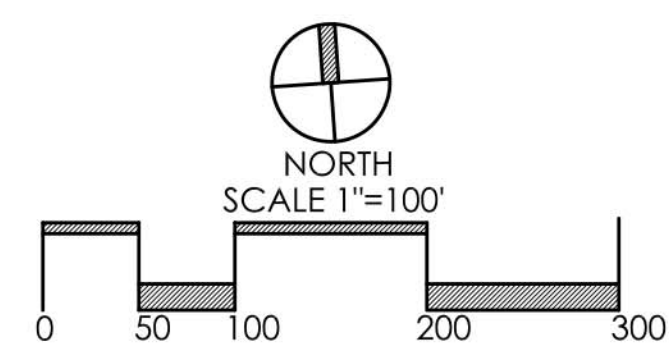

Faris Planning & Design

LAND PLANNING LANDSCAPE ARCHITECTURE
 243 N. 5th Street Suite 401 Columbus, OH 43215
 p (614) 487-1964 www.farisplanninganddesign.com

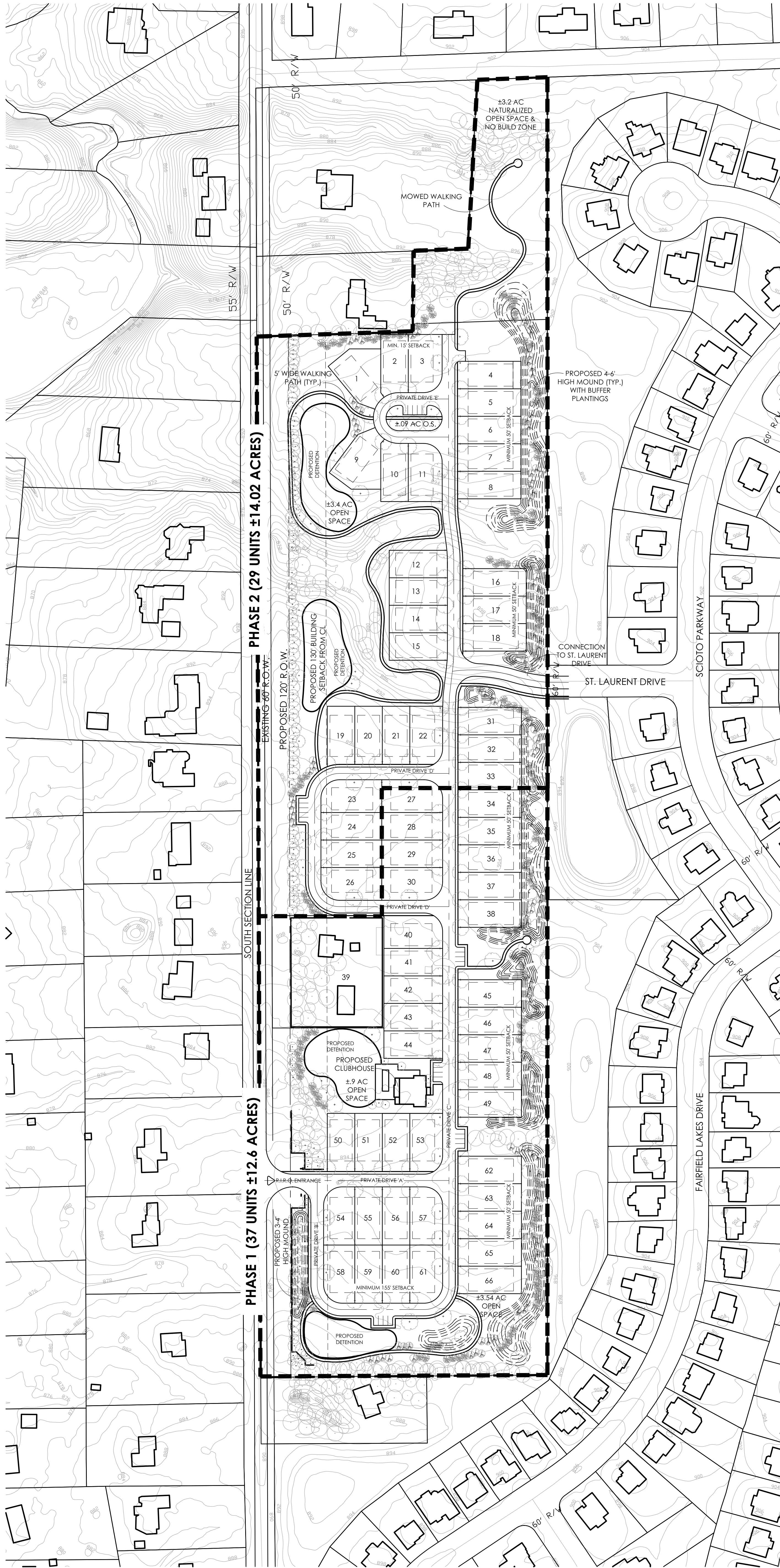

PHASING PLAN

THE COURTYARDS AT SOUTH SECTION LINE

PREPARED FOR EPCON COMMUNITIES

DATE: 7.29.15

EXHIBIT C-2

Faris Planning & Design

LAND PLANNING LANDSCAPE ARCHITECTURE

243 N. 5th Street Suite 401 Columbus, OH 43215
p (614) 487-1964 www.farisplanninganddesign.com

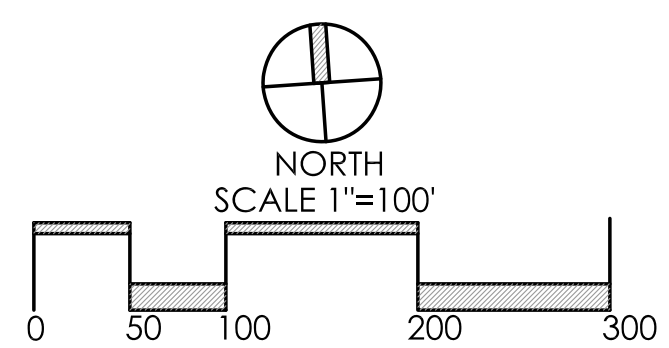

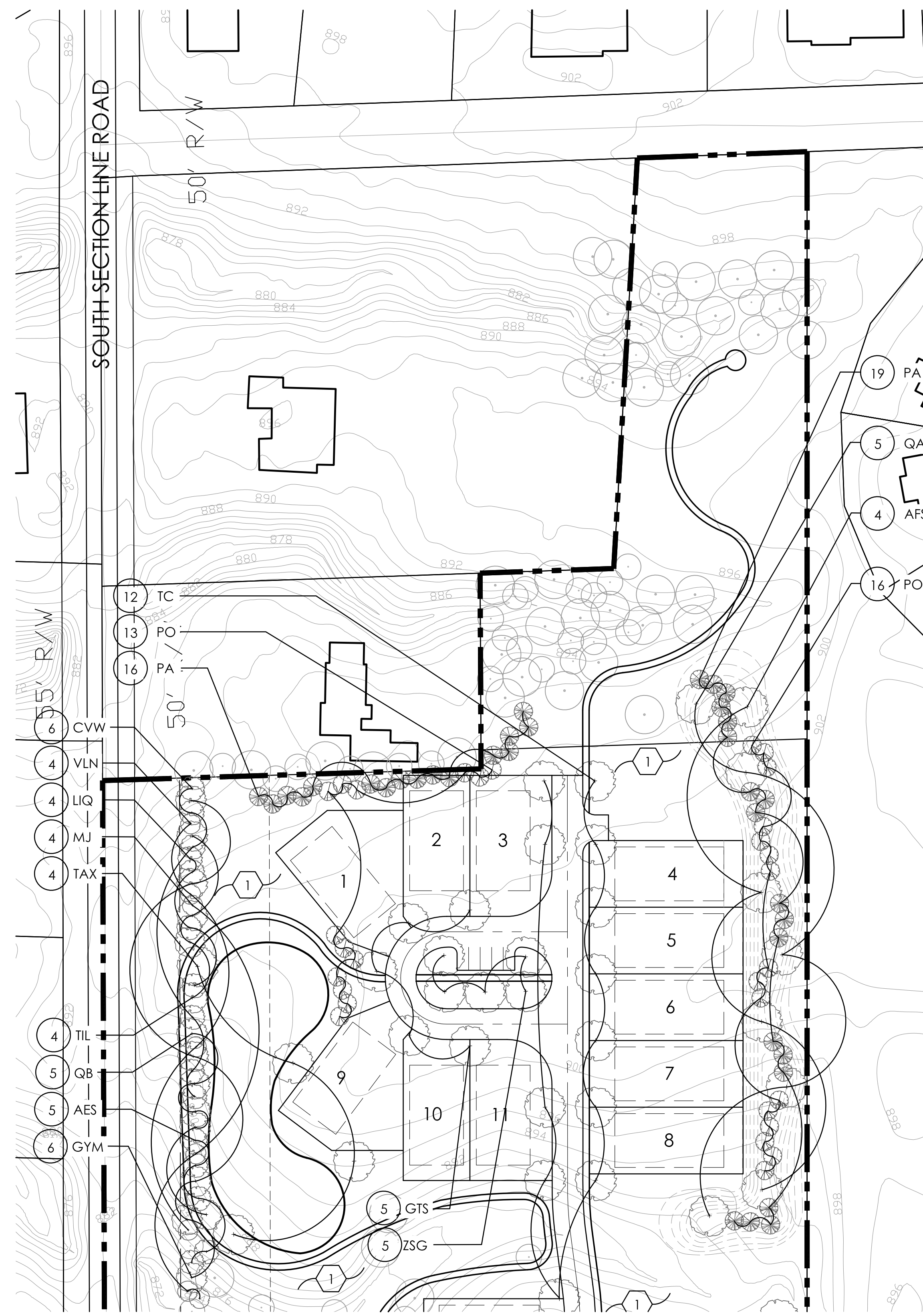

2 NORTH SITE LANDSCAPE PLAN
SCALE: 1"=60'

GENERAL PLANTING NOTES:

- ALL PLANTS SHALL MEET OR EXCEED STANDARDS SET IN THE USA STANDARD FOR NURSERY STOCK.
- ALL PLANTING OPERATIONS SHALL ADHERE TO THE AMERICAN ASSOCIATION OF NURSERYMEN STANDARDS.
- PLANT LOCATIONS AND BEDS SHALL BE LOCATED BY CONTRACTOR AND APPROVED BY LANDSCAPE ARCHITECT PRIOR TO INSTALLATION.
- PLANTING BEDS SHALL HAVE A MINIMUM 3" DEEP SHREDDED HARDWOOD BARK MULCH. MULCH HEDGES IN A CONTINUOUS BED.
- ALL PLANTING BEDS TO BE TILLED TO A MINIMUM DEPTH OF 12".
- ALL PLANTING BEDS TO BE FERTILIZED WITH 10-10-10 OR APPROVED EQUAL.
- SODDING / SEEDING BY LANDSCAPE CONTRACTOR.
- THE LOCATION OF THE EXISTING UNDERGROUND UTILITIES ARE SHOWN IN AN APPROXIMATE WAY ONLY AND HAVE NOT BEEN INDEPENDENTLY VERIFIED BY THE OWNER OR ITS REPRESENTATIVE. THE CONTRACTOR SHALL DETERMINE THE EXACT LOCATION OF ALL EXISTING UTILITIES PRIOR TO COMMENCING WORK AND AGREES TO BE FULLY RESPONSIBLE FOR ANY AND ALL DAMAGES WHICH MIGHT BE OCCASIONED BY THE CONTRACTOR'S FAILURE TO EXACTLY LOCATE AND PRESERVE ANY AND ALL UNDERGROUND UTILITIES.
- ALL AREAS DISTURBED BY CONSTRUCTION ARE TO BE RESTORED, FINE GRADED AND SEEDED/ SODDED.
- ALL EXISTING PLANT MATERIAL SHOWN ON THIS PLAN IS TO BE PRESERVED UNLESS SPECIFICALLY NOTED OTHERWISE.

CONSTRUCTION NOTES:

- 1 LAWN AREA, PROVIDE POSITIVE DRAINAGE ACROSS ALL SURFACES.
- 2 LANDSCAPE AREA, PROVIDE POSITIVE DRAINAGE ACROSS ALL SURFACES.

PLANT LIST
(CONTRACTOR RESPONSIBLE FOR ALL PLANTS SHOWN ON PLAN)

QTY	KEY	BOTANICAL NAME	COMMON NAME	SIZE	COND.	REMARKS
TREES						
57	TC	TILIA CORDATA	GREENSPIRE LITTLE LEAF LINDEN	3" CAL.	B&B	
5	ZSG	ZELKOVA SERRATA 'GREEN VASE'	GREEN VASE ZELKOVA	3" CAL.	B&B	
34	AFS	ACER FREEMANII 'SIENNA'	SIENNA GLEN MAPLE	3" CAL.	B&B	
16	AFJ	ACER FEEMANII 'JEFFSRED'	AUTUMN BLAZE MAPLE	3" CAL.	B&B	
5	GTS	GLEDITSIA TRIACANTHOS VAR. 'INERMIS 'SKYCOLE'	SKYLINE HONEYLOCUST	3" CAL.	B&B	
14	GPS	GINKGO BILOPA 'PRINCETON SENTRY'	PRINCETON SENTRY GINKGO	3" CAL.	B&B	
35	QA	QUERCUS ALBA	WHITE OAK	3" CAL.	B&B	
114	PO	PICEA OMORIKA	SERBIAN SPRUCE	8-10' HGT.	B&B	
144	PA	PICEA ABIES	NORWAY SPRUCE	8-10' HGT.	B&B	
24	SRI	SYRINGA RETICULATA 'IVORY SILK'	IVORY SILK LILAC TREE	8-10' HGT.	B&B	MULTI-STEM
10	TAX	TAXODIUM DISTICHUM	BALD CYPRESS	3" CAL.	B&B	
22	TIL	TILLIA AMERICANA	AMERICAN LINDEN	3" CAL.	B&B	
16	MJ	MAGNOLIA 'JANE'	JANE MAGNOLIA	6-7' HGT.	B&B	
14	QB	QUERCUS BICOLOR	SWAMP WHITE OAK	3" CAL.	B&B	
14	CVW	CRATAEGUS VIRIDIS 'WINTER KING'	WINTER KING HAWTHORN	2" CAL.	B&B	
15	GYM	GYMNOCLADUS DIOICA	KENTUCKY COFFEE TREE	3" CAL.	B&B	
11	AES	AESCLUSUS ARNOLDIANA 'AUTUMN SPLENDOR'	AUT. SPLENDOR HORSE CHESTNUT	3" CAL.	B&B	
9	VLN	VIBURNUM LENTAGO	NANNYBERRY VIBURNUM	2" CAL.	B&B	
10	LIQ	LIQUIDAMBAR STYRACIFLUA 'MORAIN'	MORAIN SWEETGUM	3" CAL.	B&B	

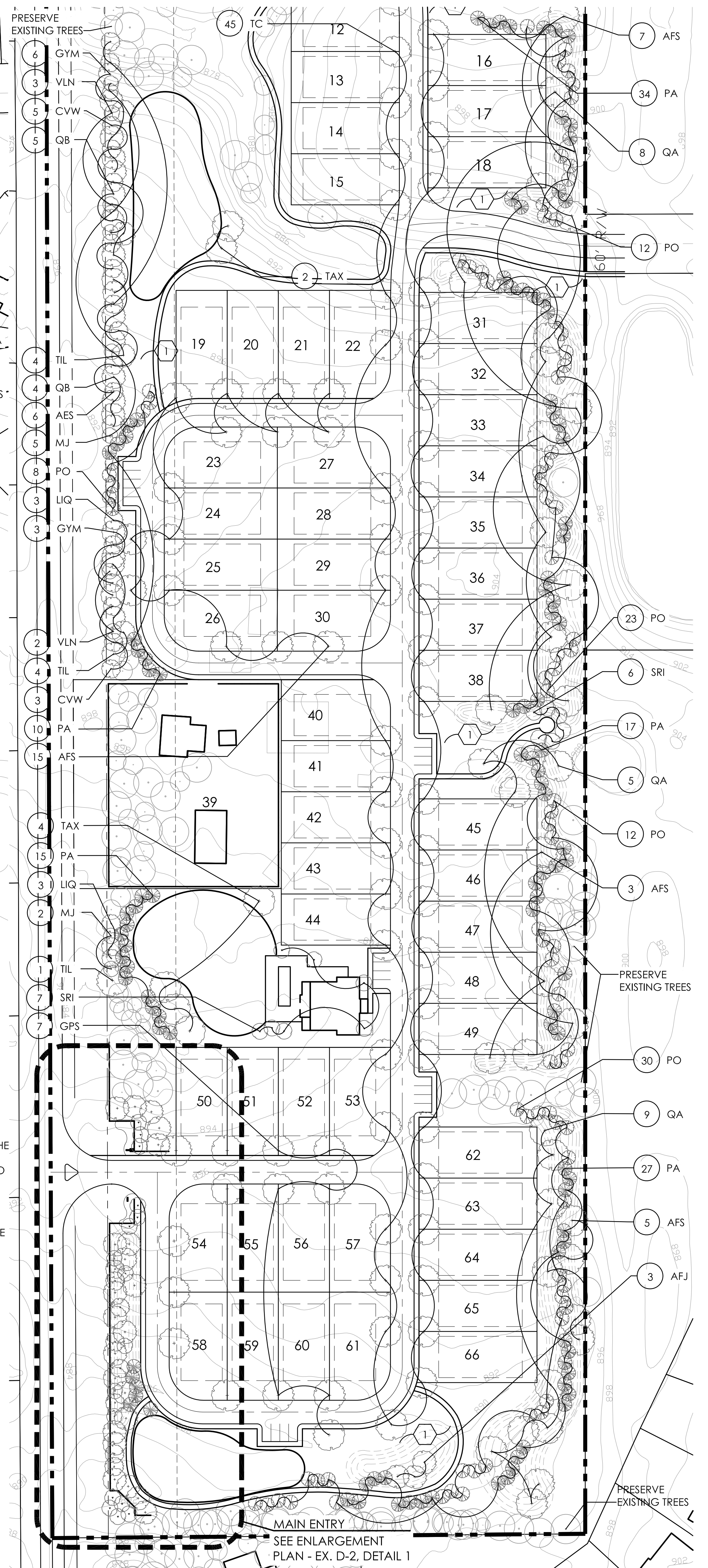

1 SOUTH SITE LANDSCAPE PLAN
SCALE: 1"=60'

PLANT KEY TYPICALS
SEE PLANT LIST FOR SPECIFIC PLANT SPECIES

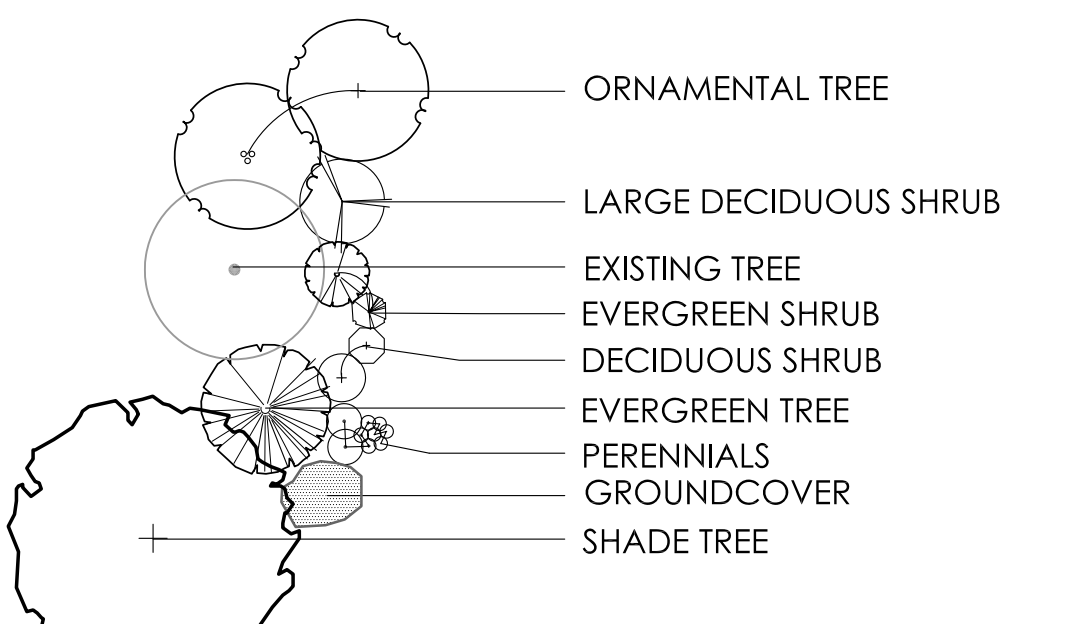

LANDSCAPE PLAN

THE COURTYARDS AT SOUTH SECTION LINE

PREPARED FOR EPCON COMMUNITIES

DATE: 7.29.15

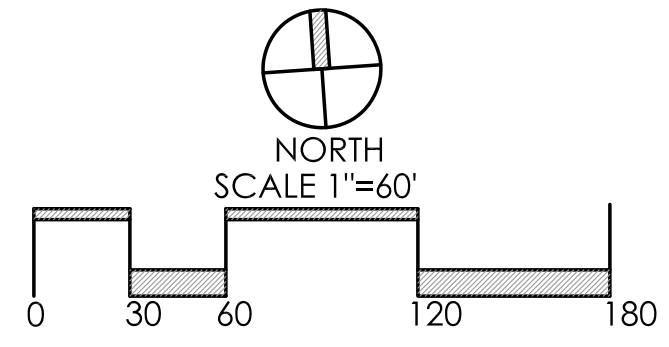

Faris Planning & Design

LAND PLANNING LANDSCAPE ARCHITECTURE
243 N. 5th Street Suite 401 Columbus, OH 43215
p (614) 487-1964 www.farisplanninganddesign.com

NOTE: 20' MIN. SETBACK FROM R.O.W. SIGNAGE TO BE SINGLE SIDED

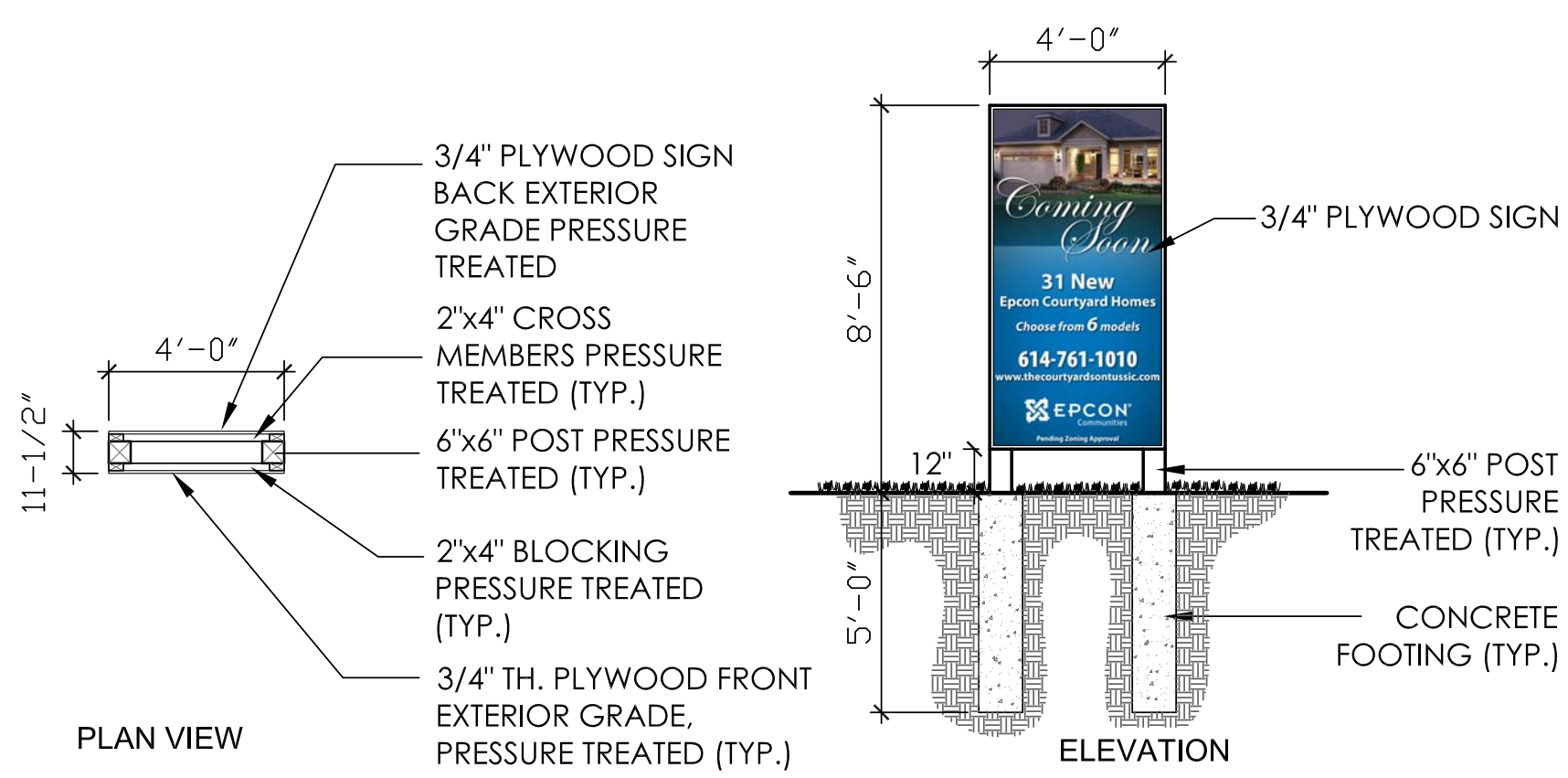

3 TEMPORARY SIGN DETAIL
N.T.S.

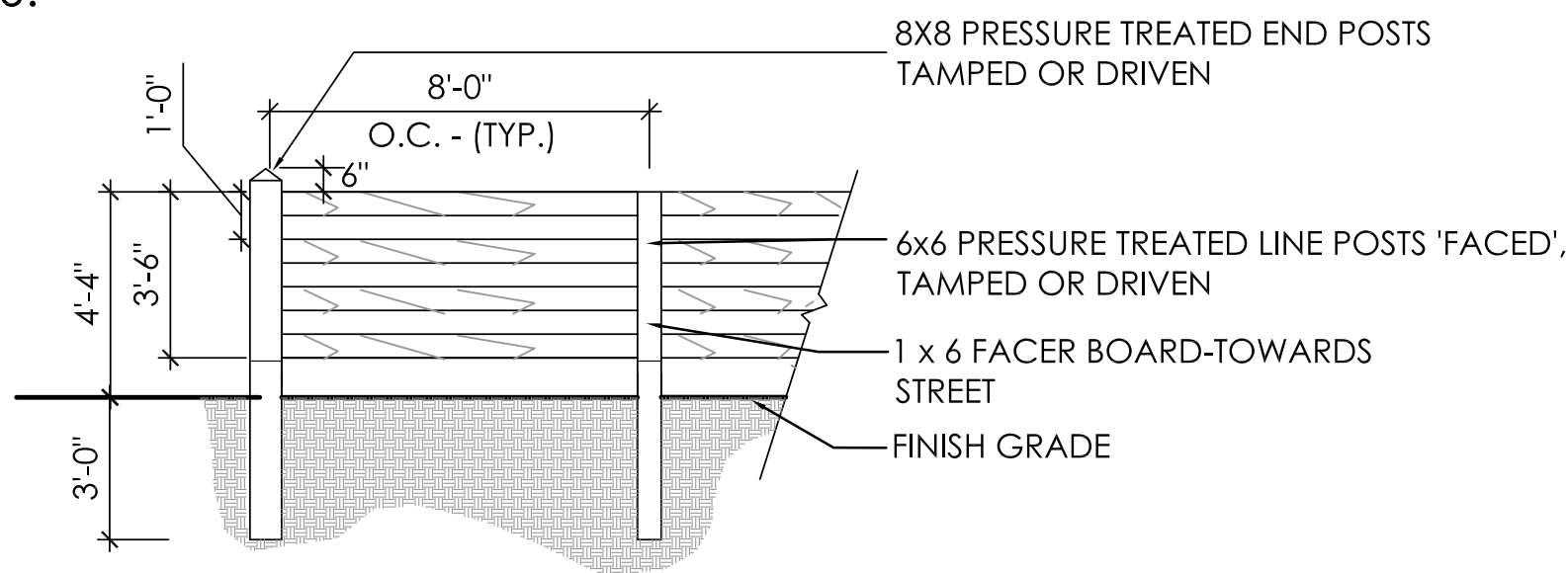

NOTES:
POSTS SHALL BE SOUND, STRAIGHT AND FREE FROM KNOTS, SPLITS, AND SHAKES, AND PEELED THEIR ENTIRE LENGTH. BOTH ENDS SHALL BE DOUBLE TRIMMED AND SAWED SQUARE

FENCE BOARDS
BOARDS SHALL BE 1" X 6" X 16' POPLAR, PRESSURE TREATED. THE BOARDS SHALL BE SOUND, STRAIGHT AND FREE OF KNOTS AND SHAKES

PAINT
PAINT SHALL BE A SEMI GLOSS BLACK

FASTENERS
NAILS-10D PLAIN SHANK BOX GALVANIZED

4 4 RAIL FENCE
N.T.S.

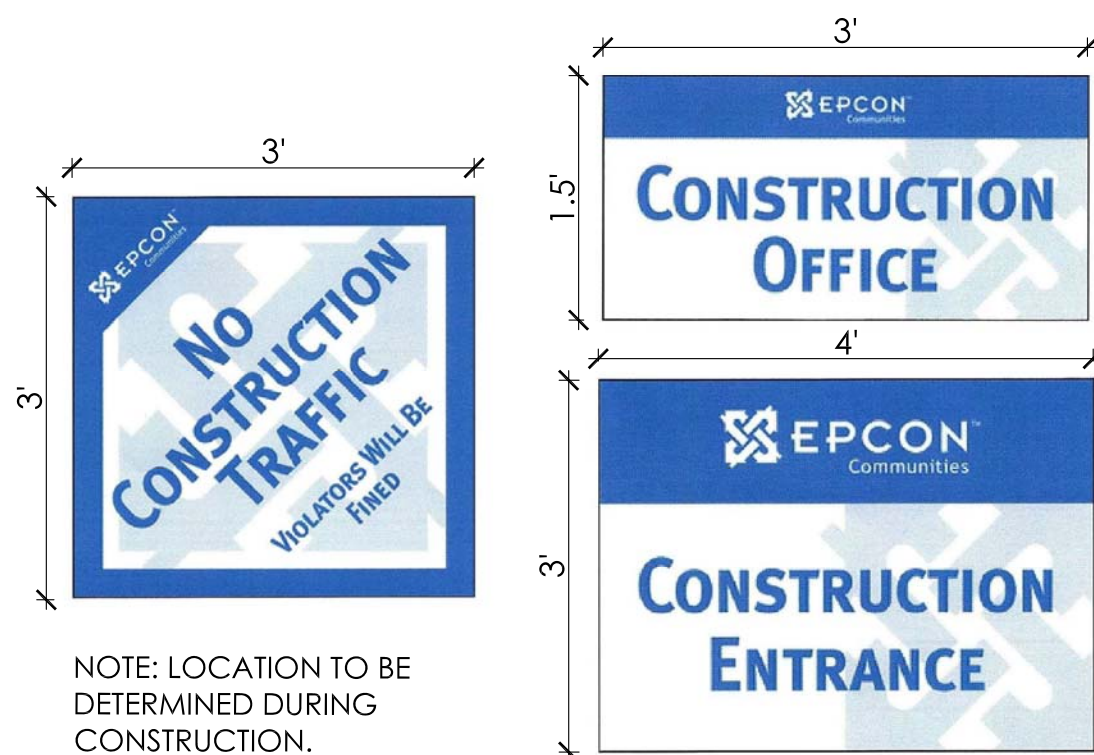

NOTE: LOCATION TO BE DETERMINED DURING CONSTRUCTION.

5 TEMPORARY CONSTRUCTION SIGNS
SCALE: NTS

GENERAL PLANTING NOTES:

- ALL PLANTS SHALL MEET OR EXCEED STANDARDS SET IN THE USA STANDARD FOR NURSERY STOCK.
- ALL PLANTING OPERATIONS SHALL ADHERE TO THE AMERICAN ASSOCIATION OF NURSERYMEN STANDARDS.
- PLANT LOCATIONS AND BEDS SHALL BE LOCATED BY CONTRACTOR AND APPROVED BY LANDSCAPE ARCHITECT PRIOR TO INSTALLATION.
- PLANTING BEDS SHALL HAVE A MINIMUM 3" DEEP SHREDDED HARDWOOD BARK MULCH. MULCH HEDGES IN A CONTINUOUS BED.
- ALL PLANTING BEDS TO BE TILLED TO A MINIMUM DEPTH OF 12".
- ALL PLANTING BEDS TO BE FERTILIZED WITH 10-10-10 OR APPROVED EQUAL.
- SODDING / SEEDING BY LANDSCAPE CONTRACTOR.
- THE LOCATION OF THE EXISTING UNDERGROUND UTILITIES ARE SHOWN IN AN APPROXIMATE WAY ONLY AND HAVE NOT BEEN INDEPENDENTLY VERIFIED BY THE OWNER OR ITS REPRESENTATIVE. THE CONTRACTOR SHALL DETERMINE THE EXACT LOCATION OF ALL EXISTING UTILITIES PRIOR TO COMMENCING WORK AND AGREES TO BE FULLY RESPONSIBLE FOR ANY AND ALL DAMAGES WHICH MIGHT BE OCCASIONED BY THE CONTRACTOR'S FAILURE TO EXACTLY LOCATE AND PRESERVE ANY AND ALL UNDERGROUND UTILITIES.
- ALL AREAS DISTURBED BY CONSTRUCTION ARE TO BE RESTORED, FINE GRADED AND SEEDED/ SODDED.
- ALL EXISTING PLANT MATERIAL SHOWN ON THIS PLAN IS TO BE PRESERVED UNLESS SPECIFICALLY NOTED OTHERWISE.

CONSTRUCTION NOTES:

- LAWN AREA, PROVIDE POSITIVE DRAINAGE ACROSS ALL SURFACES.
- LANDSCAPE AREA, PROVIDE POSITIVE DRAINAGE ACROSS ALL SURFACES.

PLANT KEY TYPICALS

SEE PLANT LIST FOR SPECIFIC PLANT SPECIES

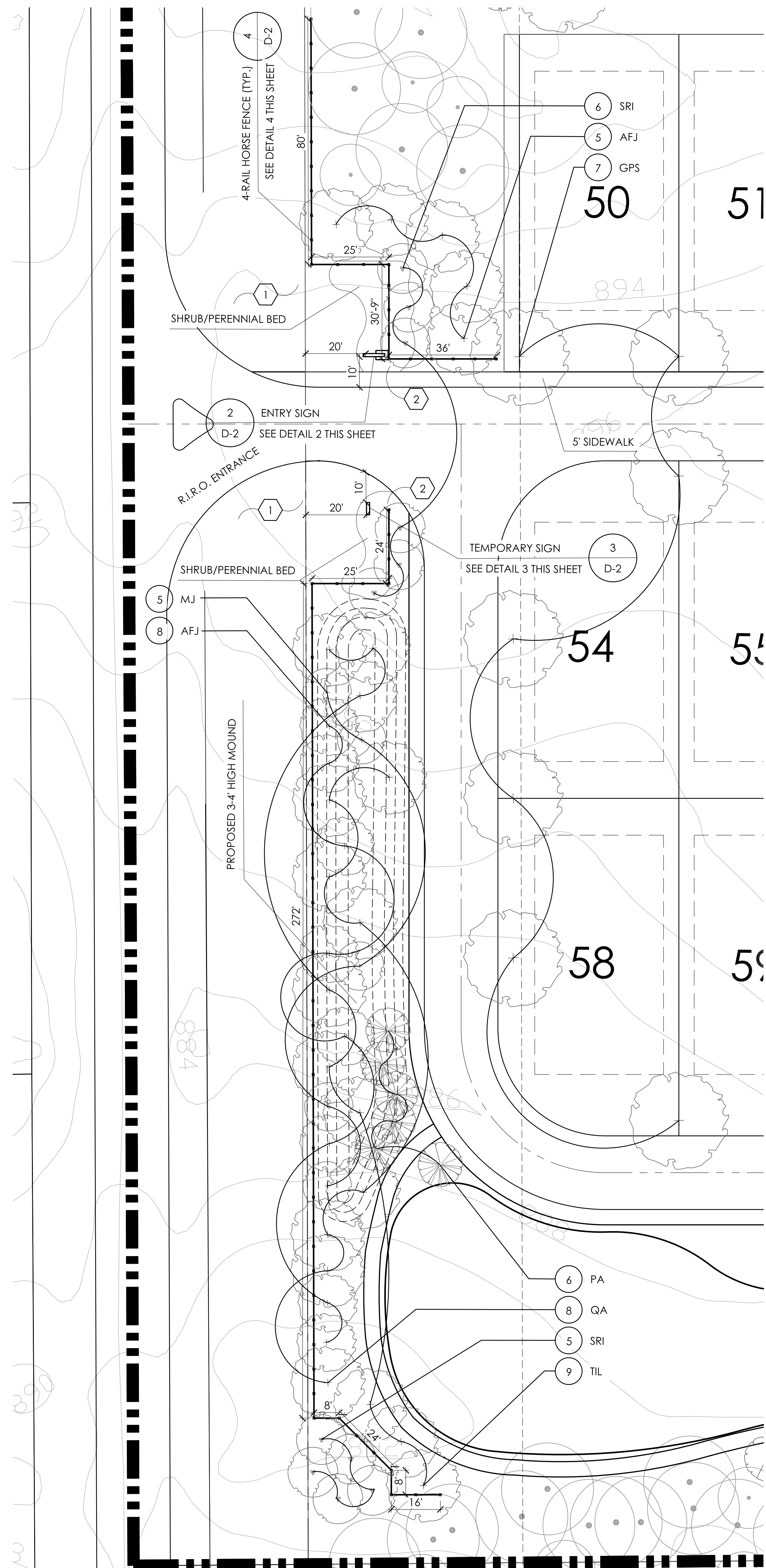
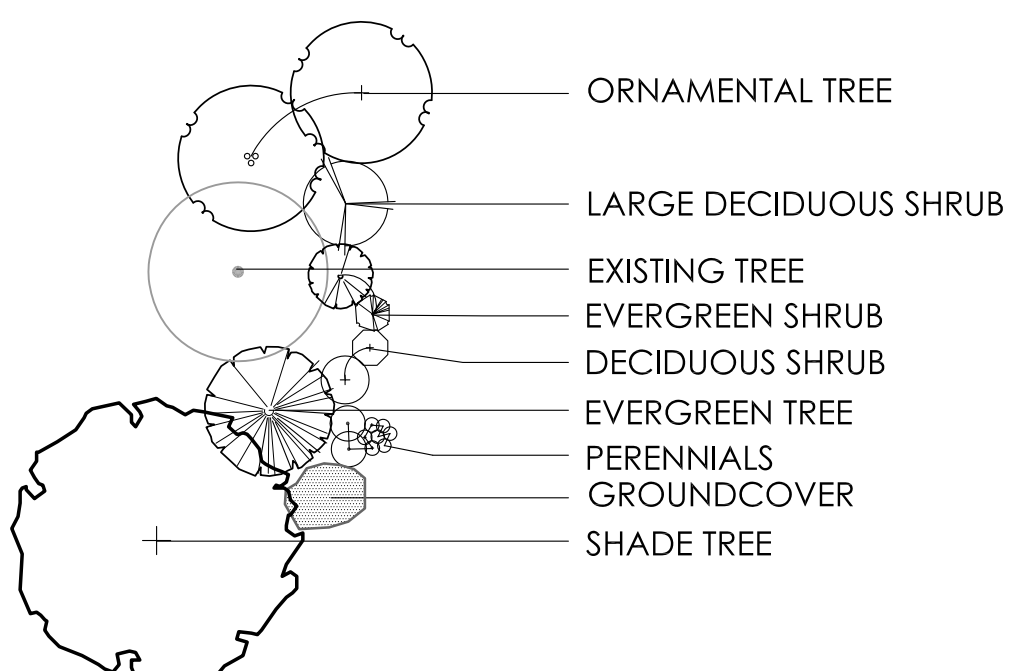

1 MAIN ENTRY ENLARGEMENT PLAN
SCALE: 1"=20'

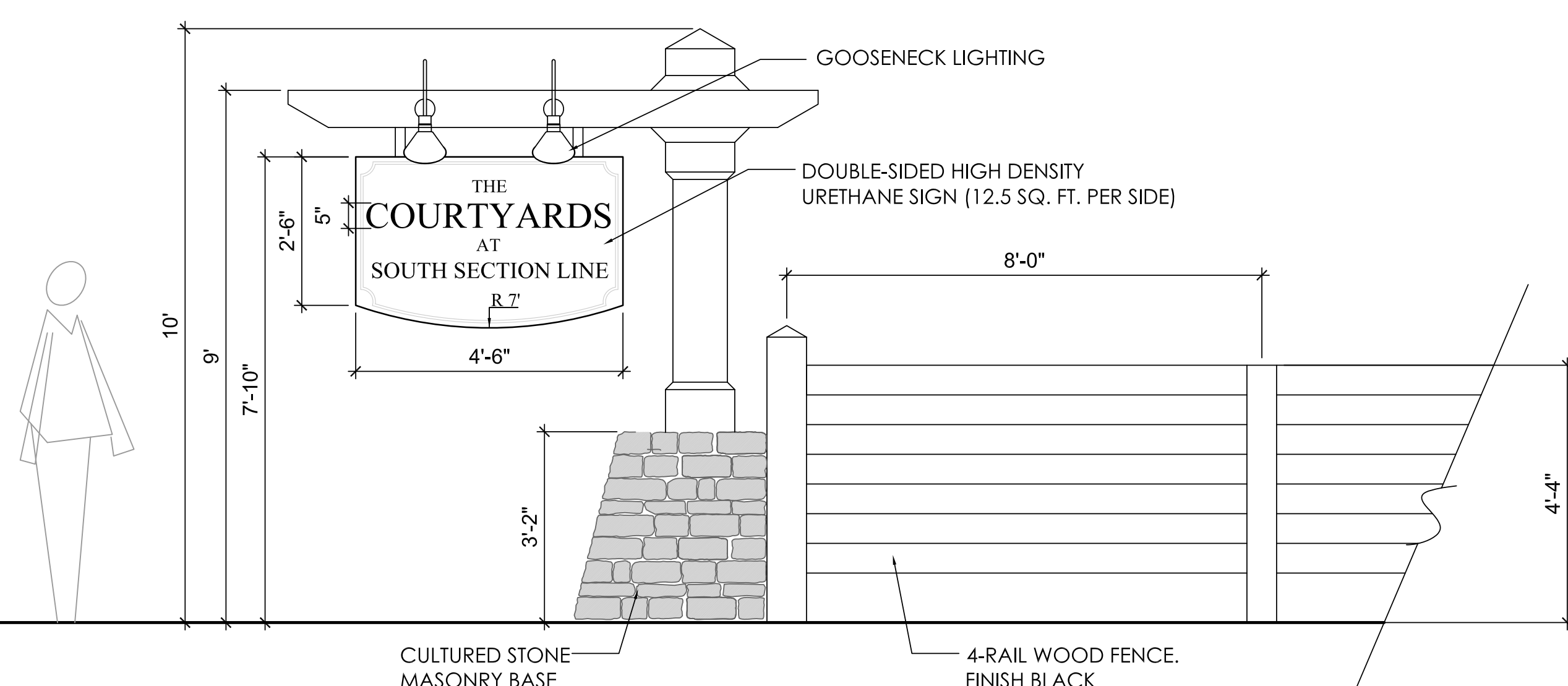

2 DOUBLE-SIDED ENTRY SIGN
N.T.S.

ENTRY ENLARGEMENT PLAN

EXHIBIT D-2

THE COURTYARDS AT SOUTH SECTION LINE

PREPARED FOR EPCON COMMUNITIES

DATE: 7.29.15

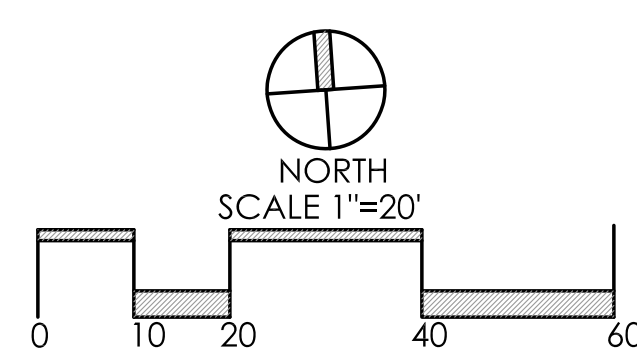

Faris Planning & Design

LAND PLANNING LANDSCAPE ARCHITECTURE
243 N. 5th Street Suite 401 Columbus, OH 43215
p (614) 487-1964 www.farisplanninganddesign.com

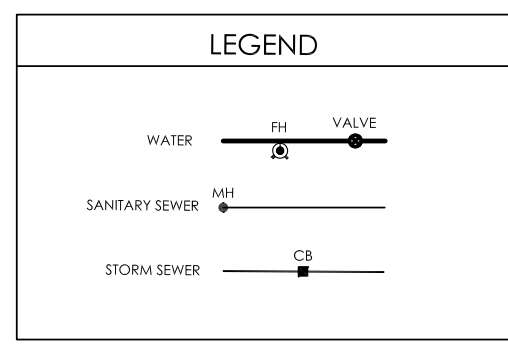
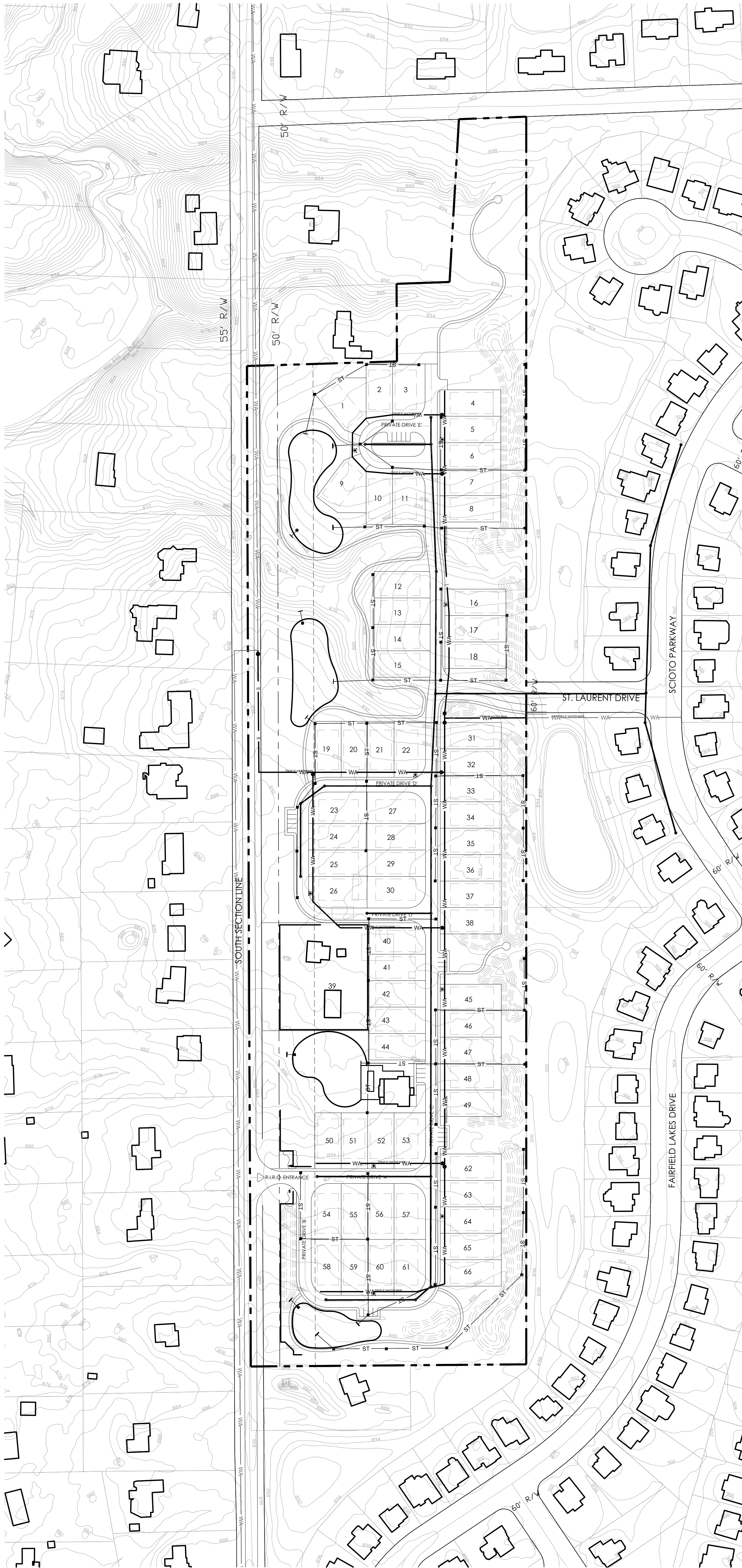

NOTE: The utility sizes and locations shown hereon are approximate only and general in nature. Minor relocations and/or changes in sizing during final engineering design are to be expected. Such changes will not affect the serviceability or viability of the project.

UTILITY PLAN

THE COURTYARDS AT SOUTH SECTION LINE

PREPARED FOR EPCON COMMUNITIES

DATE: 7.29.15

EXHIBIT E-1

Faris Planning & Design

LAND PLANNING LANDSCAPE ARCHITECTURE

243 N. 5th Street Suite 401 Columbus, OH 43215
 p (614) 487-1964 www.farisplanninganddesign.com

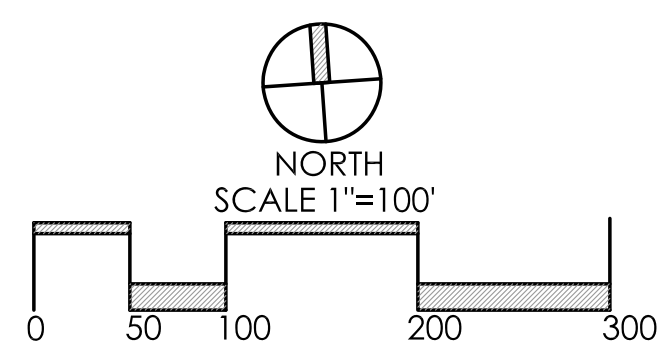

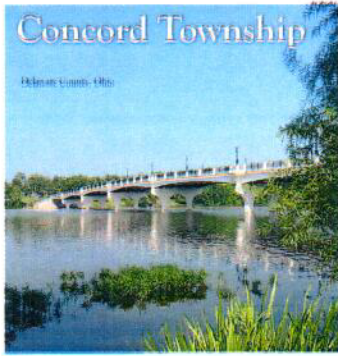

CONCORD TOWNSHIP, DELAWARE COUNTY, OHIO

Trustees:

Karen Koch
Joe Garrett
Bart Johnson

Fiscal Officer:

Jill M. Davis

Fire Chief:

Todd Cooper

June 29, 2015

Joe Thomas Jr.
Metro Development
470 Old Worthington Road
Westerville, Ohio 43082

Dear Sir:

This letter is in reference to the proposed "Courtyards at South Section Line" being developed on S. Section Line Road in Concord Township, Delaware County. I have reviewed the updated "June 2015" layout of this property. The changes to remove the gate to the east and make the one way in and out to the west meet the needs of the Concord Township Fire Department.

Sincerely,

A handwritten signature in black ink, appearing to read "Todd Cooper".

Todd

Todd Cooper
Director of Operations / Fire Chief
614-653-2580 cell

EXHIBIT E-8

6385 Home Road, Delaware, OH 43015

Phone: 740-881-5338 Fax: 740-881-5279 Email: tcooper@concordtwp.org

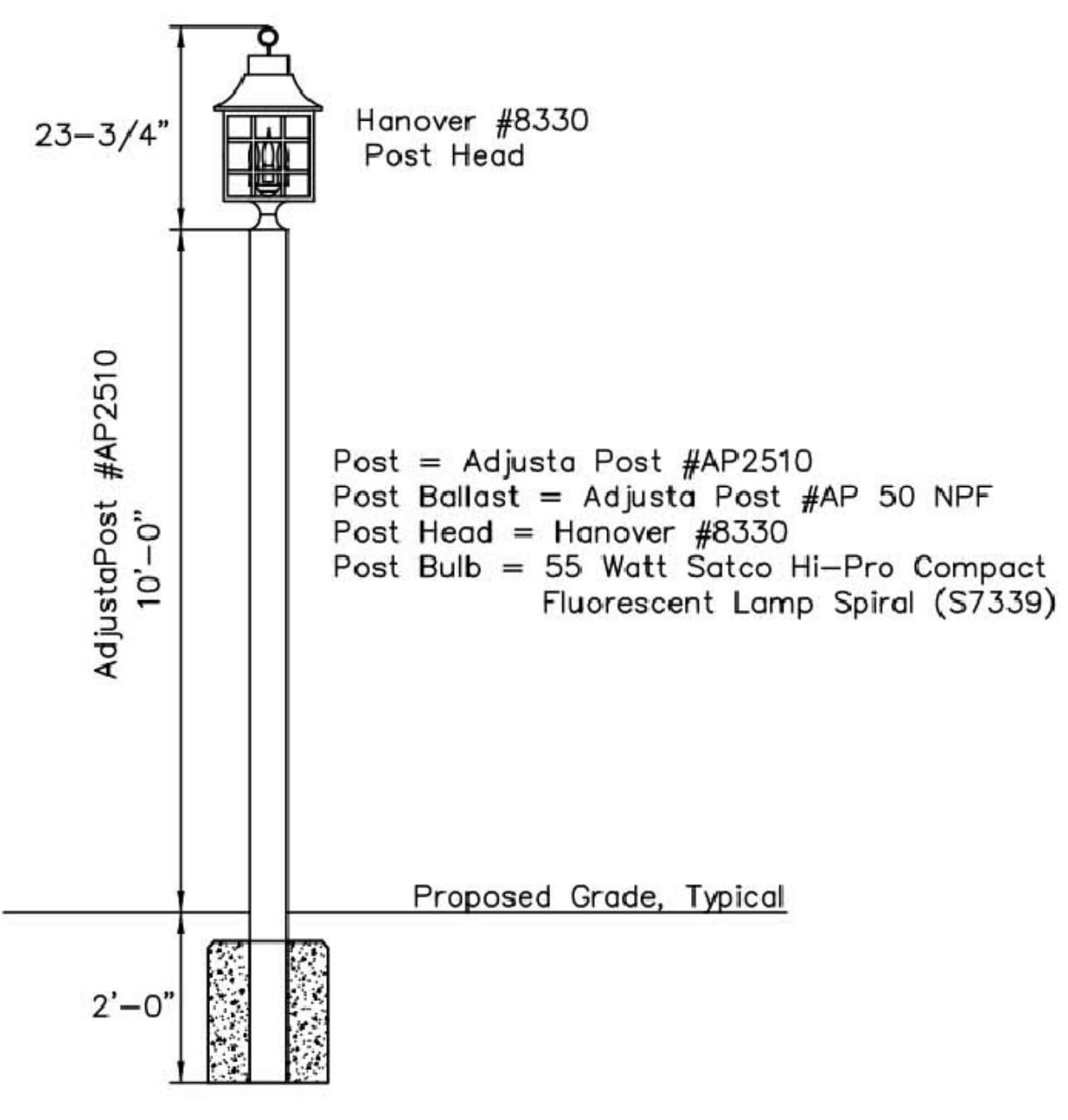
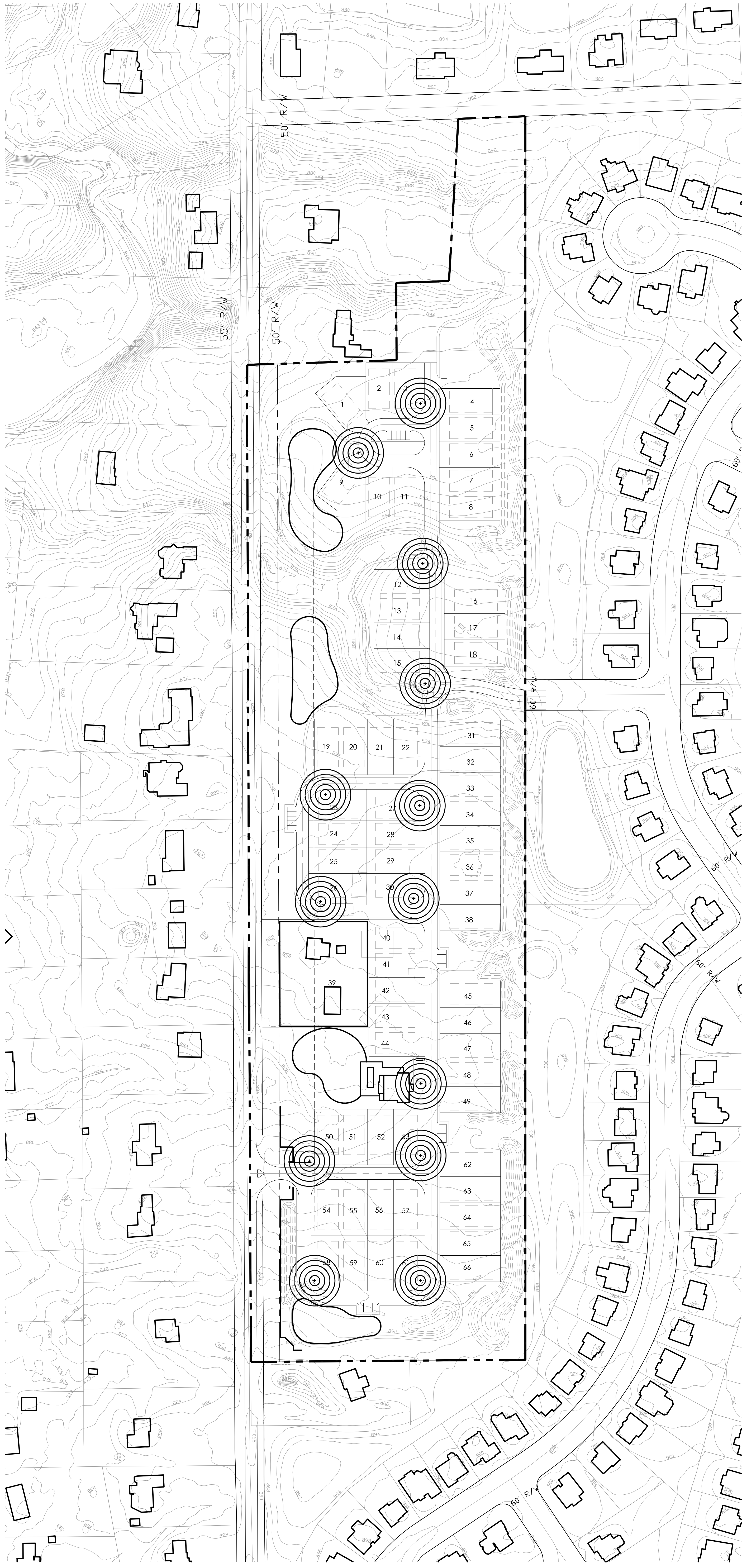

STANDARD LIGHT POLE
Not to Scale

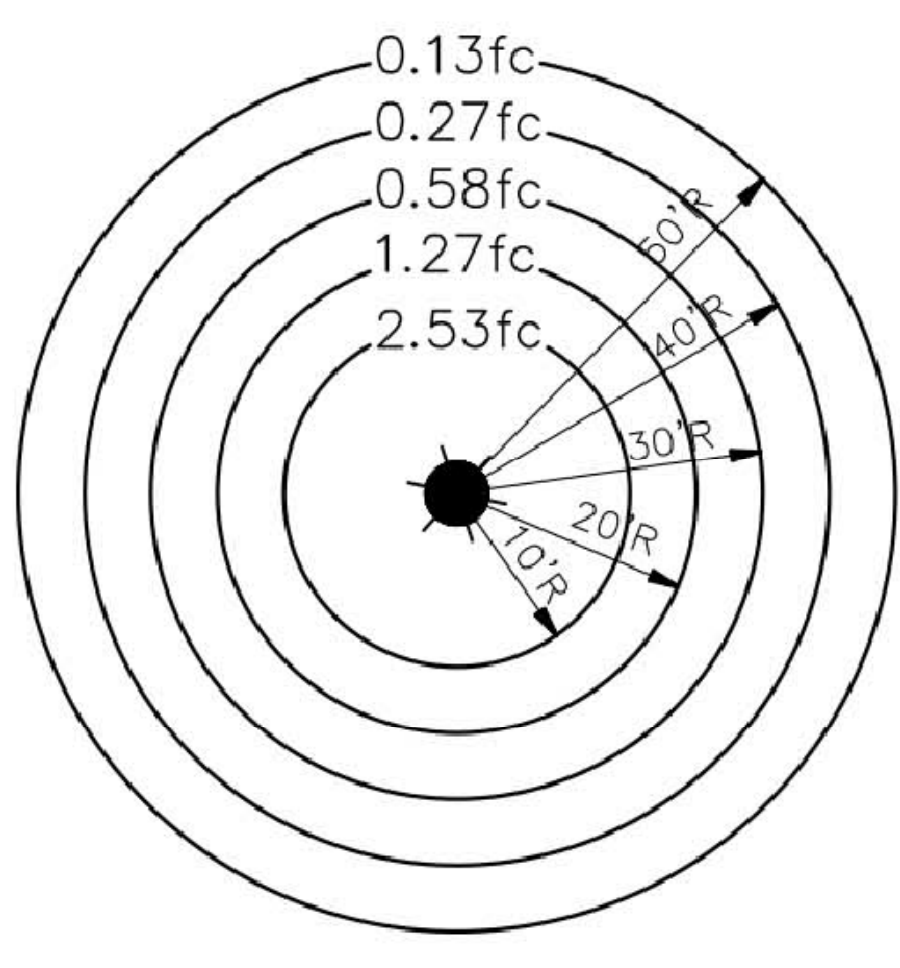

TYPICAL LIGHT POLE PHOTOMETRICS
Not to Scale

LIGHTING PLAN

THE COURTYARDS AT SOUTH SECTION LINE

PREPARED FOR EPCON COMMUNITIES
 DATE: 7.29.15

EXHIBIT J-1

Faris Planning & Design
 LAND PLANNING LANDSCAPE ARCHITECTURE

243 N. 5th Street Suite 401 Columbus, OH 43215
 p (614) 487-1964 www.farisplanninganddesign.com

